

# SaaS Without Borders

Steve Mezak, CEO  
Accelerance, Inc.

author of

***Software Without Borders:***  
*A Step-By-Step Guide to Outsourcing  
Your Software Development*





## Software Trends on Planet Earth

- Does anyone *license* software anymore?
  - Web apps around since 1995
  - Now Software as a Service
- Does anyone *program* anymore?
  - Offshoring now business as usual
  - 80% of ISVs are offshoring
- Globalization 3.0 opportunities
  - Democratization of the web
  - Emergent wisdom of crowds
  - You can change the world!

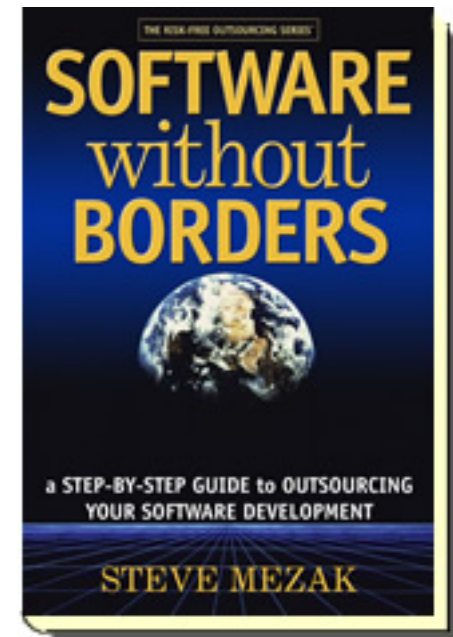

## Deciding to Outsource

- Over 80% of ISVs are offshoring
- Cost savings the #1 reason
- Project or ODC
- BOT or offshore subsidiary
- Some finding reasons not to

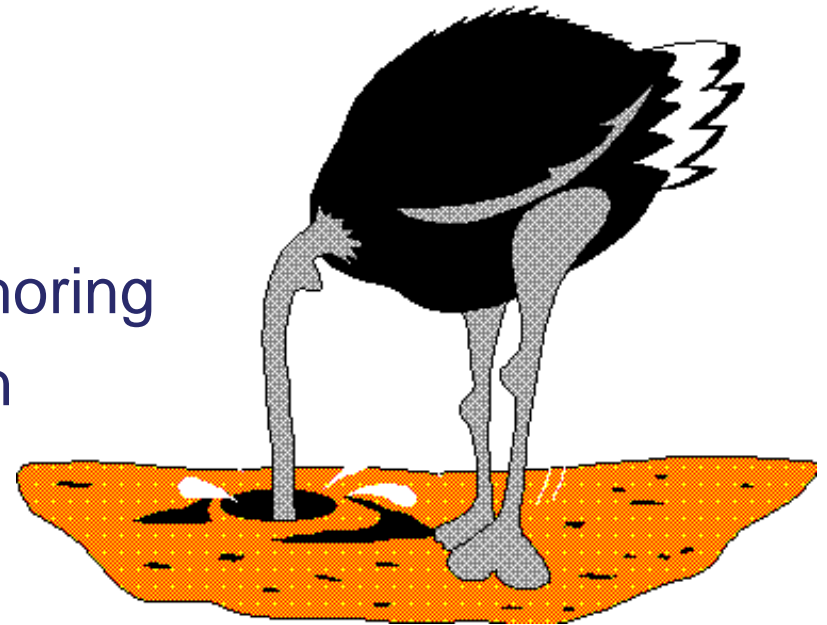

How to ignore  
offshore outsourcing



## Where to Outsource

- 80% goes to India
- Time zone issues
- Language & culture
- IPR protection

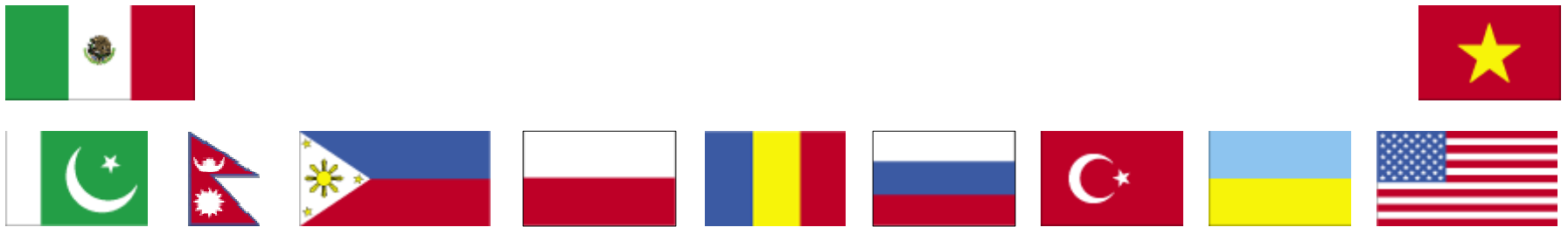
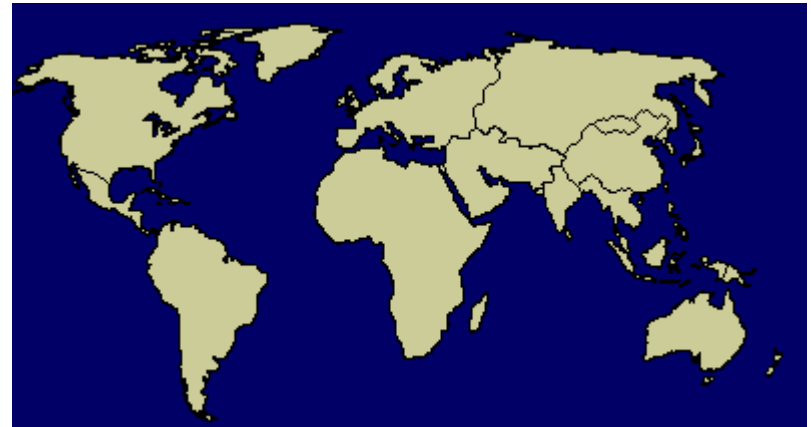

# How to Select Your Outsourcing Vendor

- Technical skills
  - Scalable web applications
  - Web 2.0 user interface
  - Database tuning
- Positive happy references
- Beware of “body shops”
- Only services, no products
- Careful evaluation can takes months



The danger of choosing  
the wrong vendor

## Creating Your Own Offshore Subsidiary

- Only for > 50 engineers
- Lower costs – 1/3 rule
- Build, Operate & Transfer
- Fixed vs. variable cost
- Beach head in new market
- IP > Subsidiary



Your new offshore  
operation

## Designing Your Software for Outsourcing

- Requirements but no long specs
- Use cases or user stories
  - Who & how
- SaaS Transformation
  - Use screen shots of existing app
- Screen mock-ups in HTML
  - Link to demo for prospects

Extracting use cases from  
an Accelerance client



## Controlling Your Outsourced Software Development

- Keeping in touch with your team
  - Email, IM & VOIP
- Agile & test-driven development
  - Frequent iterations
  - Users as part of development process
  - Test first, then write code
- On-line system for tracking outsourcing
- Travel



# Software Outsourcing Metrics

- New product development
  - Lines of code over time
  - Features or work units per day
  - Actual vs. estimated schedule
- Maintenance programming
  - Time per bugs fix
  - Amount of rework
- Practical Software Measurement - PSM
- Balanced Scorecards
  - Financial, customer, process & learning perspectives

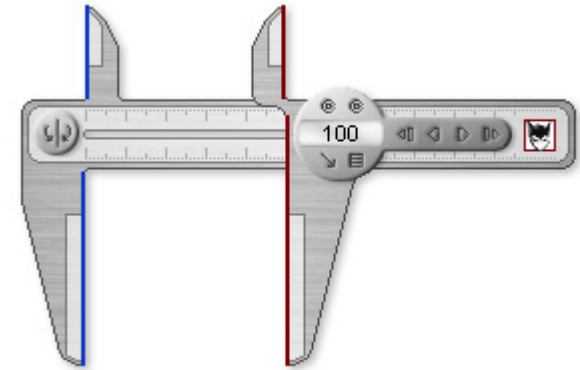

# Protecting Your Intellectual Property

- 5 levels of IP risk
  - *Very low* - standard / old tech widely available and understood
  - *Low* - some IP exposed but practical use by others is limited
  - *Neutral* - some IP exposed, partition software to limit danger
  - *Moderate* - consider using multiple teams to limit access to all IP
  - *Serious* - risk may overwhelm the benefits of outsourcing
- 3 kinds of protection
  - Technical, Legal & Physical
- Open source licensing dangers

# Outsourcing Your Quality Assurance

- Requirements Testing
  - making sure your software does what you designed it to do
- Usability Testing
  - specialized testing that may require focus groups of target users
- Load or Stress Testing
  - ensure your software has the required performance
- Environment Testing
  - testing your software on different operating systems, browsers, etc.
- Regression Testing
  - automated process to repeat tests quickly on each new release

# Special Projects Suited for Outsourcing

- SaaS transformation
- Five steps for new product development
  1. Describe
  2. Demo
  3. Customer Discovery
  4. Write an MRD
  5. Outsource development
- Using the latest technical craze
  - AJAX, mobile, digital video

**AJAX**



# The Future of Outsourcing

- Globalization 3.0
  - A flat world of freelancers
  - And smaller, agile vendors
  - Not just multinationals
- New countries & regions
  - South America
  - Middle East
  - Africa
- Vendor selection by industry & domain experience

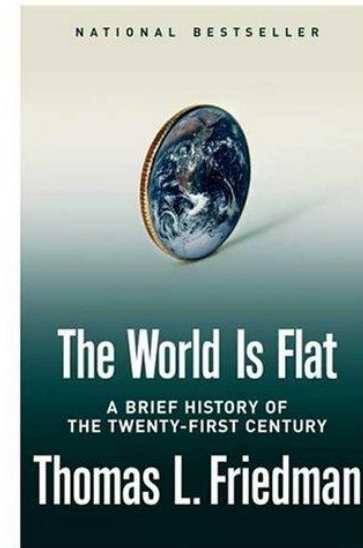

## Summary

- SaaS helps you reach the globe
  - Will you expand *your* borders?
  - Will you change the world?
- Globalization 3.0 is here
  - Resistance is futile
  - Use it to your advantage
- Still risks and dangers
  - Pick the right vendor quickly
  - Use the right software development process



## Outsourcing Info & Services from Accelerance

- Free Report: *The Seven **Deadly** Dangers of Outsourcing*
- Free Bi-weekly *Runtime* eZine
  - Do's and Don'ts of outsourcing
  - Latest trends
- *Software Without Borders* book – April publication
- New low-cost Outsourcing Jumpstart service - \$497
  - Contacts with 5 pre-qualified vendors
  - By country and/or technology
  - Fourteen-page vendor selection guide
  - Hour of expert consulting to help make final selection

